

CATERPILLAR TOLERANCE REPRESENTATIONS

NANCY EATON AND GLENN FAUBERT

ABSTRACT. Various families of tolerance graphs of subtrees for specific families of host trees and tolerance functions have been successfully characterized. For example, chordal graphs are intersection (tolerance 1) graphs of subtrees of general trees, see [2], [5], and [8]. Intersection graphs of subtrees of a path are those that are chordal and do not contain an asteroidal triple, see [7]. We denote by $\text{cat}[h, t]$ the tolerance graphs of subtrees where the host is a caterpillar of maximum degree h and the tolerance function is the constant t for all vertices. We give a characterization involving asteroidal triples with no simplicial vertices for the equivalent families $\text{cat}[3, 1]$, $\text{cat}[3, 2]$, and $\text{cat}[h, 1]$ for all $h \geq 3$. We also prove that $\text{cat}[4, 2] = \text{cat}[3, 3]$ and that $\text{cat}[h, 2] \subsetneq \text{cat}[h - 1, 3]$ for $h \geq 5$.

1. INTRODUCTION

A *tolerance subtree representation* (T, \mathcal{H}, t) of a connected graph $G = (V, E)$ consists of a *host* tree T and a family of subtrees $\mathcal{H} = \{H_u : u \in V\}$ of T such that $uv \in E$ if and only if $|V(H_u) \cap V(H_v)| \geq t$. The parameter t is a positive integer called the *tolerance of the representation*. A graph that has such a representation is called a *tolerance subtree graph*.

It has been shown by Jameson and Mulder in [6] that all graphs have a tree tolerance representation of tolerance 2. That the set of graphs with representation of tolerance 1 are precisely the chordal graphs is due separately, to Buneman, Gavril, and Walter and can be found in [2], [5], and [8], respectively.

A *caterpillar* is a tree which contains a path, P , such that every vertex is either in or adjacent to P . When a subtree tree tolerance representation uses a caterpillar as the host we call it a *caterpillar tolerance representation*, and the corresponding graphs are called *caterpillar tolerance graphs*.

The set $\text{cat}[h, t]$ will denote the family of caterpillar tolerance graphs where the host caterpillar has maximum degree h and the tolerance of the representation is t . Note that $\text{cat}[2, t]$ is the class of graphs

representable with tolerance t where the host is a path. This class is completely understood. Due to a characterization by Lekkerkerker and Boland in [7], we know that this class consists of chordal graphs that do not contain an asteroidal triple. An *asteroidal triple* is a set of three vertices v_1, v_2, v_3 in a graph such that for any permutation, (v_i, v_j, v_k) , of these vertices, there exists a $v_i v_j$ -path that v_k is not adjacent to.

We generalize representations on a path by absorbing graphs representable by a path into our class $\text{cat}[2,1]$. In this paper we provide a characterization of $\text{cat}[3,1]$, and since, as we shall show, $\text{cat}[3,1] = \text{cat}[h,1] = \text{cat}[3,2]$ for $h \geq 3$, we obtain characterizations for these other classes as well.

2. EXAMINING THE CLASSES

For all integers $h \geq 3$ and $t \geq 1$, the authors have determined exactly which cycles are in $\text{cat}[h, t]$, see [3]. The results are given in table 1, where the largest cycle in a class is indicated and implies that all smaller cycles are included as well. A glance at the results in Table 1 raises the question of which classes having longest cycle C_3 are equal. In fact, $\text{cat}[h,1]$ is the same for all $h \geq 3$, as we shall see, but they are all different from $\text{cat}[2,t]$ despite having identical longest cycle lengths. The added structure of a caterpillar over that of the path allows for the representation of new graphs. Table 1 also suggests the possibility that $\text{cat}[3,2]$ may be the same set of graphs as $\text{cat}[3,1]$, and that $\text{cat}[4,2]$ is the same as $\text{cat}[3,3]$. It turns out that both of these observations will also bare fruit.

	$t = 1$	$t = 2$	$t = 3$	$t \geq 4$
$h = 2$	C_3	C_3	C_3	C_3
$h = 3$	C_3	C_3	C_4	all
$h = 4$	C_3	C_4	all	all
$h \geq 5$	C_3	C_h	all	all

TABLE 1. The maximum cycle representable by $\text{cat}[h, t]$

3. PRELIMINARIES

The following terms and conventions will be used in the proofs throughout this paper. For clarity the word *node* will be used to refer to a vertex of the host caterpillar to distinguish it from the vertices of a represented graph. Let the *spine*, S , of the caterpillar be a the longest

path to which all other nodes of the caterpillar are adjacent. We will denote by S_v the set $V(H_v) \cap V(S)$. The nodes of the spine will be named s_1, s_2, \dots, s_m with adjacencies $s_i s_{i+1}$ for $1 \leq i \leq m - 1$, and we will say that s_i is *to the left of* s_j just when $i < j$. Similarly, we will say s_i is *to the right of* s_j just when $i > j$. Any node that is not on the spine is called a *foot*. Every foot is adjacent to exactly one spinal node. Multiple feet adjacent to the same spinal node, s_i will be denoted, $f_{i,1}, f_{i,2}, \dots, f_{i,3}$.

For $v \in V(G)$, we will use the usual notation, $N(v)$, to denote neighbors of v in G . This notion can be extended naturally to any set of vertices of G . For $U \subseteq V(G)$ we will denote the neighborhood of U by $N(U)$, to be the set $\{w \in V(G) \setminus U : uw \in E(G) \text{ for some } u \in U\}$. A vertex $v \in G$ is said to be *simplicial* if $N(v)$ induces a clique in G .

The *Helly property* is a property that intersecting families of sets might have. See Berge's textbook, [1], on hypergraphs for an exposition of various incarnations of the Helly property. We will say that a graph G has the *Helly property* if for any family of subgraphs $\{G_1, G_2, \dots, G_k\}$ of G , $V(G_p) \cap V(G_q) \neq \emptyset$ for $p, q \in \{1, \dots, k\}$ implies that $\bigcap G_i \neq \emptyset$.

We will now state without proof, two theorems about the monotonic behavior of class inclusion for caterpillar subtree representations with respect to maximum caterpillar degree and tolerance. The first result is easy to see but the second is non-trivial. For a proof of these results, see [3].

Theorem 3.1. *For $h, t \in \mathbf{Z}^+$, $\text{cat}[h, t] \subseteq \text{cat}[h + 1, t]$.*

Theorem 3.2. *For $h \geq 2$ and $t \geq 1$, $\text{cat}[h, t] \subseteq \text{cat}[h, t + 1]$.*

To show that caterpillar hosts allow for the representation of more graphs than mere path hosts, we find a graph which is in $\text{cat}[3, 1]$ but not in $\text{cat}[2, 1]$. We can then conclude by Theorem 3.1 that such a graph is in $\text{cat}[h, 1]$ for any $h \geq 3$. The graph we use is the subdivision of $K_{1,3}$ on seven vertices shown in figure 1. We will call it G^* .

By Lekkerkerker and Boland's characterization of path representations, G^* is not in $\text{cat}[2, 1]$ because of the presence of the asteroidal triple labelled w_1, w_2 , and w_3 . However G^* has the following tolerance 1 subtree representation by a caterpillar of degree 3: Let the host, H , be a caterpillar of maximum degree 3 and let s_1, s_2, s_3 be three consecutive spinal nodes of H with corresponding foot nodes f_1, f_2, f_3 . Label the central vertex of G^* by u , the neighbors of u as v_1, v_2, v_3 , and label the leaves as w_1, w_2, w_3 , with w_i adjacent only to v_i , $i = 1, 2, 3$. The

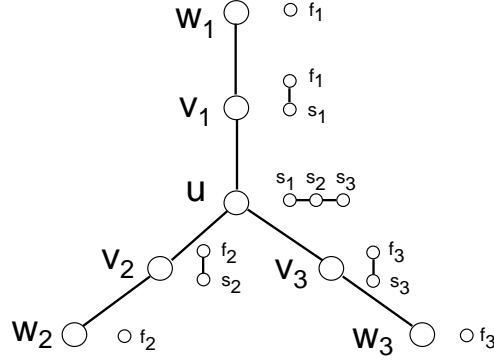

FIGURE 1. The graph G^* is in $\text{cat}[3,1]$ but not in $\text{cat}[2,1]$

subtrees are assigned to the vertices of G^* as follows: H_u is assigned nodes s_1, s_2, s_3 ; H_{v_i} is assigned nodes s_i and f_i , $i = 1, 2, 3$; and H_{w_i} is assigned node f_i , $i = 1, 2, 3$. Thus the following theorem has been proved.

Theorem 3.3. *For $h \geq 3$, $\text{cat}[h, 1] \neq \text{cat}[2, 1]$.*

4. EQUIVALENT CLASSES

We now establish the result that increasing the maximum degree of the caterpillar host beyond three does not allow the subtree representation of any additional graphs when the tolerance is one. A host construction will be used in the proof of Theorem 4.2, Theorem 4.3, and Theorem 5.1. We will define it here. See Figure 2 for an example of this construction when $h = 5$.

Definition 4.1. Given a caterpillar host H of maximum degree $h \geq 3$, define H^* to be the caterpillar of maximum degree $\max\{h - 1, 3\}$ with spine $s''_1, s'_1, s''_2, s'_2, \dots, s''_m, s'_m$. Where both s''_i is adjacent to s'_i for $1 \leq i \leq m$ and s'_i is adjacent to s''_{i+1} for $1 \leq i \leq m - 1$. If $h \geq 4$ then adjacent to each node, s''_i , will be the feet $f'_{i,1}, f'_{i,2}, \dots, f'_{i,h-3}$, and adjacent to s'_i , will be the foot $f'_{i,h-2}$. If $h = 3$ then the nodes, s'_i will have no adjacent feet for all i , and adjacent to s''_i , will be the lone foot $f'_i = f'_{i,1}$.

Theorem 4.2. *For $h \geq 3$, $\text{cat}[h, 1] = \text{cat}[3, 1]$.*

Proof. Let $h \geq 4$. Theorem 3.1 implies $\text{cat}[h,1] \supseteq \text{cat}[3,1]$. We show that $\text{cat}[h,1] \subseteq \text{cat}[h-1,1]$ for $h \geq 4$. Let $G \in \text{cat}[h,1]$ with host H

and representation $\{H_v\}_{v \in V(G)}$. We construct a new host $H' = H^*$. Now we construct a new subtree representation, $\{H'_v\}_{v \in V(G)}$ on H' as follows. If the subtree, H_v , contains $f_{i,j}$, then H'_v will contain $f'_{i,j}$. If the subtree, H_v , contains s_i , then H'_v will contain s'_i and s''_i . Note that any two subtrees, H'_u , and H'_w will share in H' the corresponding nodes that H_u and H_w shared in H , plus they will share s''_i if and only if H_u and H_w shared s_i in H . \square

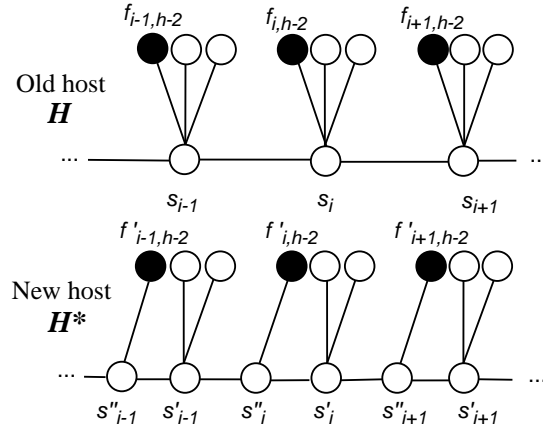

FIGURE 2. Example of H^* when $h = 5$.

And now we will show that for caterpillars of maximum degree 3, the set of graphs representable with a caterpillar subtree representation of tolerance 2 is precisely the set of graphs representable with a tolerance 1 representations.

Theorem 4.3. *The sets $cat[3, 2]$ and $cat[3, 1]$ are equal.*

Proof. We have $cat[3,2] \supseteq cat[3,1]$ from Theorem 3.2. For the inclusion, $cat[3,2] \subseteq cat[3,1]$, let $\{H_v\}_{v \in V(G)}$ be a caterpillar tolerance representation in a host, H , with maximum degree 3 and tolerance 2. We construct a new host, $H' = H^*$.

We assign the subtrees H'_v of the new host H' with the following rule: If H_v contains $s_i s_{i+1}$ in H then H'_v will contain node s'_i in the new host H' . If H_v contains the edge $s_i f_i$ in H then H'_v will contain the node f'_i in H' . We add the spinal node s''_i of H' to H'_v if and only if it contains two nodes from the neighborhood, $\{s'_{i-1}, s'_i, f'_i\}$, of s''_i , so that H'_v will be connected..

Note that since no H_u may contain only a single node of H , it follows that $\forall u \in V(G)$, H'_u must contain at least one node of H' . If u, w are

nonadjacent vertices and $|H_u \cap H_w| = 0$ then, assuming without loss of generality that H_u is completely left of H_w , there exists a rightmost spinal node s_k of H_u and a leftmost spinal node s_l of H_w with $k < l$. By the construction, the rightmost spinal node that H'_u might use is s'_k and the leftmost spinal node that H'_w might use is s''_l . Since s'_k is left of s''_l , it follows that $|H'_u \cap H'_w| = 0$. If u, w are nonadjacent vertices and $|H_u \cap H_w| = 1$, then $V(H_u) \cap V(H_w)$ is a single spinal node, s_i , hence $|H'_u \cap H'_w| = 0$. If u, w are adjacent vertices then for a node $y \in V(H_u) \cap V(H_w)$ we have $y' \in V(H_u) \cap V(H_w)$. \square

5. EXCHANGING DEGREE FOR TOLERANCE

The next theorem shows another class inclusion for caterpillar tolerance representations. Roughly speaking, we find that in some cases we can decrease the degree of the host provided we increase the tolerance of the representation and not lose any graphs. The following theorem states this result.

Theorem 5.1. *For all $h \geq 4$, $\text{cat}[h, 2] \subseteq \text{cat}[h - 1, 3]$.*

Proof. Assume that a graph G has a caterpillar tolerance representation $\{H_v\}_{v \in V(G)}$ on a host H with a maximum degree of h and tolerance 2. Our new host, H' , is the caterpillar H^* of Definition 4.1.

We assign the subtrees as follows. If a vertex, v , of G uses a node in H_v it will use the corresponding node in H'_v . In addition, if H_v contains either s_i or $f_{i, h-2}$ then H'_v will be given s''_i as well. For all pairs of subtrees which shared two or more nodes of H , their corresponding subtrees in H' will now share three or more nodes of H' . Those pairs of subtrees which were disjoint in H will remain so in H' . Lastly, we note that if $|H_u \cap H_w| = 1$ then this intersection must consist of a spinal node s_i only, so then $H'_u \cap H'_w$ consists of s'_i and s''_i only. Hence $\{H'_v : v \in V(G)\}$ is a caterpillar tolerance representation of G in H' with maximum degree $h - 1$ and tolerance 3. \square

Our next theorem shows that the inclusion obtained in Theorem 5.1 can be extended to equality in the case where $h = 4$, that is, we show that $\text{cat}[4, 2] = \text{cat}[3, 3]$.

Theorem 5.2. *The classes of graphs, $\text{cat}[4, 2]$ and $\text{cat}[3, 3]$ are equal.*

Proof. We know $\text{cat}[4, 2] \subseteq \text{cat}[3, 3]$ from Theorem 5.1. Assume that G has a caterpillar tolerance representation $\{H_v\}_{v \in G}$ in a host H with maximum degree 3 and tolerance 3. We will construct a new host, H' , with maximum degree 4 and a caterpillar tolerance representation,

$\{H'_v\}_{v \in V(G)}$, with tolerance 2. The new host caterpillar, H' , has spine s'_1, s'_2, \dots, s'_m . Adjacent to spinal node s'_i are two feet, $f'_{i,r}$ and $f'_{i+1,l}$, for $i = 1 \dots m$. The subtrees of H' are assigned to each vertex, v , of G as follows. If H_v contains $s_{i-1}s_i$ then H'_v will contain s'_i .

If H_v contains f_i then H_v must also contain s_i and either s_{i-1} or s_{i+1} , since each subtree must contain at least three nodes. If H_v contains f_i and s_{i-1} then H'_v will contain $f'_{i,l}$. If H_v contains f_i and s_{i+1} then H'_v will contain $f'_{i,r}$.

Let u and w be distinct vertices of G . Note that for no pair of vertices, $u, v \in V(G)$ will have the property that H'_u and H'_v will share a node unless H_u and H_v share an edge. Thus if $|H_u \cap H_w| < 2$ then $|H'_u \cap H'_w| = 0$. If $|H_u \cap H_w| = 2$ then either $|H'_u \cap H'_w| = 1$ or $|H'_u \cap H'_w| = 0$ depending on whether the shared nodes in H are both spinal or not, respectively. Hence all non-edges of G are preserved. If $|H_u \cap H_w| = 3$ then either all three shared nodes are spinal or two are spinal and one is a foot. Either way $|H'_u \cap H'_w| = 2$. If $|H_u \cap H_w| > 3$ then $|H'_u \cap H'_w| \geq 2$. Hence all edges of G are preserved as well.

Hence, $\text{cat}[4,2] = \text{cat}[3,3]$. \square

6. THE CHARACTERIZATION OF $\text{CAT}[\mathbb{H}, 1]$

We will use Theorem 6.1 of Lekkerkerker and Boland from [7] rewritten in terms of caterpillar tolerance subtree representations in the proof of the characterization result. We will also need Theorem 6.2 proved separately by Buneman, Gavril, and Walter in [2],[5], and [8], respectively.

Theorem 6.1. *A graph G is in $\text{cat}[2, t]$ if and only if G is chordal and contains no asteroidal triples.*

Theorem 6.2. *The set of chordal graphs is precisely the set Tolerance subtree graphs with tolerance 1.*

Finally, we will use the fact that all trees have the Helly property. Theorem 6.3 and proof can be found in [1] by Berge.

Theorem 6.3. *If G is a tree, then G has the Helly property.*

We now present a property which, together with the property of being chordal, will provide the characterization we are seeking.

Definition 6.4. We say that a graph G has an *asimplicial asteroidal triple* if there exists in G an asteroidal triple v_1, v_2, v_3 , none of which is simplicial.

The main result follows in which we will characterize the set of all graphs that can be represented by a caterpillar of degree 3 with a subtree representation of tolerance 1.

Theorem 6.5. *A graph G has a $\text{cat}[3, 1]$ subtree representation if and only if G is chordal and G has no asimplicial asteroidal triple.*

Proof. If G is not chordal, then G has an induced cycle of length at least 4. But by Theorem 6.2, such a graph has no caterpillar tolerance representation in a host with maximum degree 3 and tolerance 1. Now we assume for contradiction that G contains an asimplicial asteroidal triple using the vertices v_1, v_2, v_3 , and that G has a $\text{cat}[3, 1]$ subtree representation with representational subtrees $H_{v_1}, H_{v_2}, H_{v_3}$. Since each one of v_1, v_2, v_3 is not simplicial, then none of their representative subtrees, can be a single node. Hence, each must use a spinal node. Since these three subtrees are disjoint we can fix an orientation of the host and name the subtrees H_{v_l}, H_{v_m} , and H_{v_r} according to its position along the spine. Any path from v_l to v_r in G will have a sequence $\{H_{v_l} \dots H_{v_m} \dots H_{v_r}\}$ of sequentially intersecting subtrees in the host. Since H_{v_m} uses a spinal node, v_m , it will be adjacent to every path from v_l to v_r . But this contradicts the fact that v_1, v_2 , and v_3 form an asteroidal triple. Hence no graph can be both in $\text{cat}[3, 1]$ and contain an asimplicial asteroidal triple.

Next we assume that G is chordal and that G has no asimplicial asteroidal triples. Let S be the set of simplicial vertices of G . Let G' be the graph induced by the vertex set $V(G) \setminus S$. The graph G' has no asteroidal triples since at least one vertex of any asteroidal triple must be in S . By Theorem 6.1, there exists a subtree representation, $\{H'\}_{v \in G'}$ on a host path, H' . We partition the set S into k maximal cliques, S_1, S_2, \dots, S_k . Note that there can be no edge between two vertices coming from two distinct vertex sets, S_i and S_j , because this would contradict that S_i and S_j are maximal sets of simplicial vertices. Let $T_p = N(S_p)$. The vertices in S_p are simplicial so T_p is a clique forcing the subtrees $\{H_v\}_{v \in T_p}$ to be a pairwise intersecting family of sets. Thus by Theorem 6.3, $\bigcap_{v \in T_p} H_v$ contains some node, s'_{T_p} , of H' .

Now we will construct a new host, H , consisting of a set of spinal nodes, s_1, s_2, \dots, s_m , with $s_i s_{i+1} \in E(H)$ for $i = 1, \dots, m - 1$. For each $p = 1 \dots k$, H will have a foot, f_p , attached to s_{T_p} . (Note that s_{T_i} may be the same node as s_{T_j} even though $i \neq j$. That is, H will have k feet but each need not be adjacent to a distinct spinal node.) We assign subtrees of H to the vertices of G as follows. For each vertex $v \in S_p$, let $H_v = \{f_p\}$. For each vertex $v \in G \setminus S$, we set $H_v = H'_v \cup \{f_p : v \in T_p, p \in [d]\}$. This construction results in

a caterpillar tolerance representation for G on a host with maximum degree $h \geq 3$ and with tolerance 1. Hence by Theorem 4.2, $G \in \text{cat}[3,1]$. \square

Corollary 6.6. *A graph G is in $\text{cat}[h, 1]$ for $h \geq 3$ if and only if G is in $\text{cat}[3, 2]$ if and only if G is chordal and G has no asimplicial asteroidal triple.*

Proof. Follows directly from Theorems 6.5 and 4.2 and 4.3. \square

7. CONCLUDING REMARKS

Further questions arise when considering Table 1. We know that even though $\text{cat}[3,4]$ contains all cycles, it doesn't contain all graphs. In fact in [4], Eaton, Füredi, Kostochka, and Skokan, find that when we restrict the maximum degree of the host tree to be 3, the minimum t such that $K_{n,n}$ has a tolerance subtree representation on such a host tree is at least $\log_2 n$. The question remains as to whether or not $\text{cat}[4,3]$ or in $\text{cat}[3,4]$. Perhaps another class of graphs can be used to distinguish classes in which all cycles can be represented.

REFERENCES

- [1] C. Berge. *Hypergraphs: Combinatorics of Finite Sets*, North-Holland mathematical library. **v. 45** (1989), 21-26.
- [2] P. Buneman. *A characterization of rigid circuit graphs*, Discrete Math. **9** (1974), 205-212.
- [3] N. Eaton, G. Faubert. *Caterpillar Tolerance Representations of Cycles*, Preprint.
- [4] N. Eaton, Z. Füredi, A. Kostochka, and J. Skokan. *Tree Representations of graphs*, Preprint.
- [5] F. Gavril. *The intersection graphs of subtrees in trees are exactly the chordal graphs*, J. Combinatorial Theory Ser. B **16** (1974), 47-56.
- [6] R. E. Jameson and H. M. Mulder. *Constant tolerance representations of graphs in trees*, Proceedings of the Thirtieth Southeastern International Conference on Combinatorics, Graph Theory and computing (Boca Raton, FL 2000) Congr. Numer., vol. 143, 2000, 175-192.
- [7] C. G. Lekkerkerker and J. Ch. Boland. *Representation of a finite graph by a set of intervals on the real line*, Fund. Math. **51** (1962/1963), 45-64.
- [8] J. R. Walter. *Representations of chordal graphs as subtrees of a tree*, J. Graph Theory **2** (1978) no. 3, 265-267.

UNIVERSITY OF RHODE ISLAND, KINGSTON, RI 02881
E-mail address: `eaton@math.uri.edu`

UNIVERSITY OF RHODE ISLAND, KINGSTON, RI 02881
E-mail address: `gfaubert@math.uri.edu`